

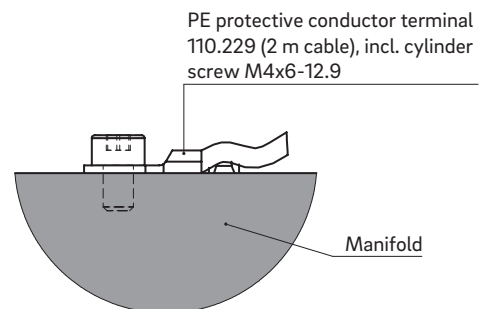

Cross manifold type KCP4/KDP4

Manifold length (VL) 180

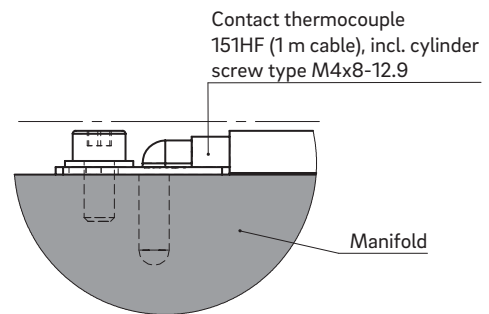
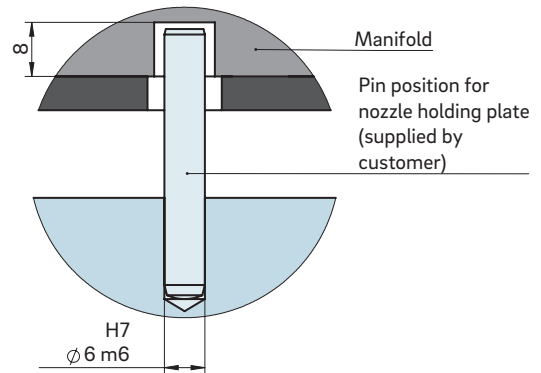

TECHNICAL DATA

KCP4/KDP4 180

Manifold height (VH) KCP: 36 mm
KDP: 46 mm

Operating voltage 230 V_{AC}*

Manifold length (VL) 180

Pin position (SP) 59.0

Control circuits 1

Power (watts) per control circuit 2 ×
1000

*Volts alternating current

WEBCODE
25070

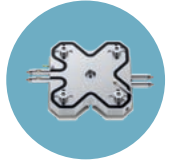

INSTALLATION

Nozzle tip view

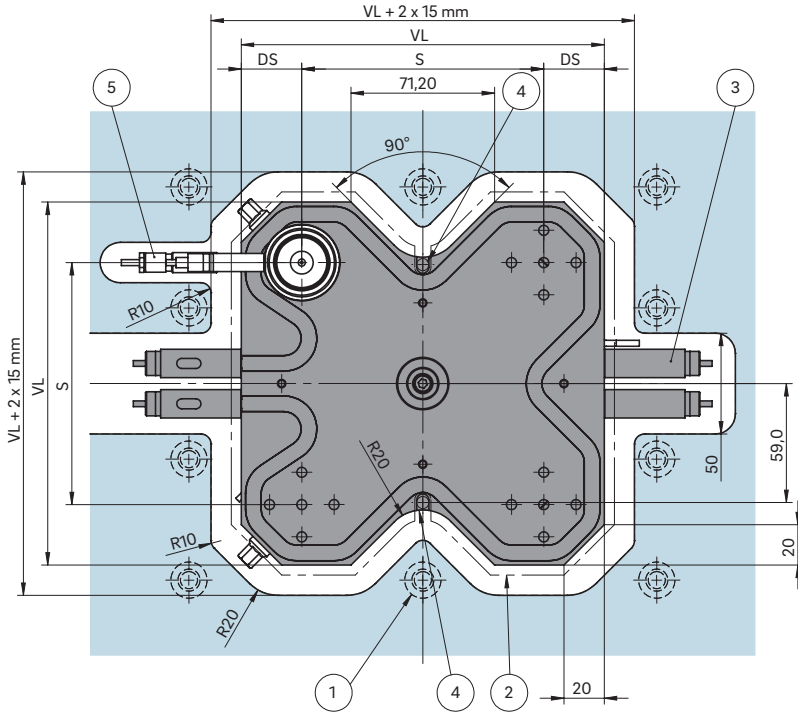

DS Edge distance:
 a. min. 35.0 with nozzle size ≤ 6
 b. min. 45.0 with nozzle size 8 or 10
 c. min. 50.0 with nozzle size ≥ 12

S Pitch between the nozzles

- ① Screw connection close to manifold
- ② High-temperature insulation plate
- ③ Heating connections
- ④ Possible pin position
- ⑤ Opening and plug location dependent upon nozzle type

Manifold height (VH)

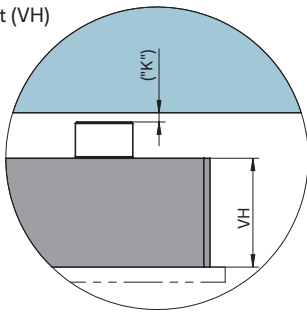

Dimension "K" required for heat expansion is to be ensured by grinding the pressure piece (12 + 0.1 mm)! Determine the difference between the height of the manifold system and the height of the frame plate when installed! ΔT specifies the temperature differential between the processing temperature and the mould temperature!

VH	ΔT (°C)	100	150	200	250	300	350
36 mm	K (mm)	0.021	0.059	0.098	0.137	0.177	0.217
46 mm	K (mm)	0.033	0.078	0.124	0.170	0.218	0.264

Design examples/Balancing

Type		KCP = 36 (VH) Melt channel $\varnothing d$ in mm	KDP = 46 (VH) Melt channel $\varnothing d$ in mm	Number of drops
K_P4B		≤ 10	≥ 12 to 16	4
		DS min. 35	DS min. 50	

B = balanced