

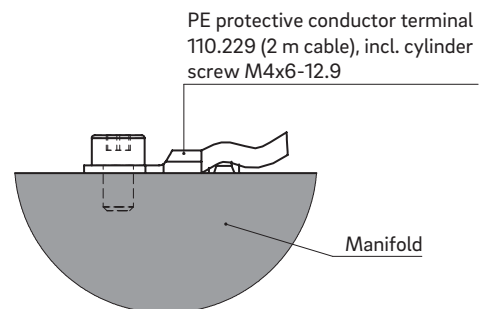

Straight manifold type GDP

Manifold length (VL) 160-360

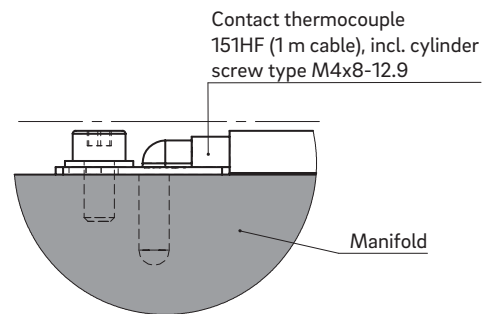
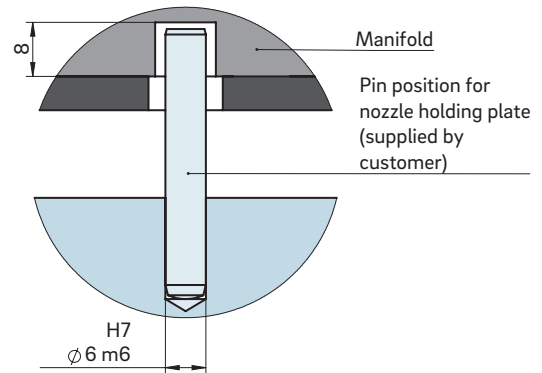

TECHNICAL DATA

GDP VL 160-360

Manifold height (VH) 46 mm

Operating voltage 230 V_{AC} *

| Manifold length (VL) | 160 | 210 | 260 | 310 | 360 |
|-----------------------------------|---------|---------|----------|----------|----------|
| Control circuits | 1 | 1 | 1 | 1 | 1 |
| Power (watts) per control circuit | 2 x 750 | 2 x 950 | 2 x 1000 | 2 x 1350 | 2 x 1500 |

*Volts alternating current

WEBCODE
25030



INSTALLATION

Nozzle tip view

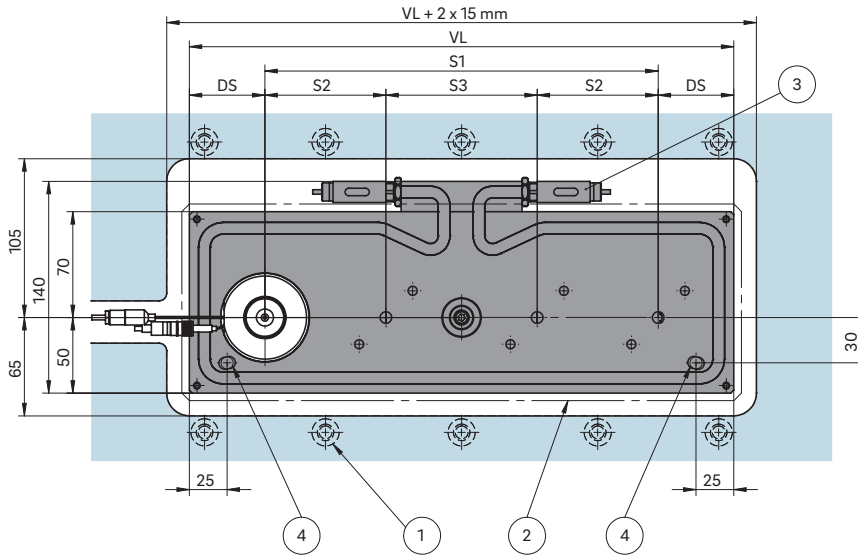

DS Edge distance:
 a. min. 35.0 with nozzle size ≤ 6
 b. min. 45.0 with nozzle size 8 or 10
 c. min. 50.0 with nozzle size ≥ 12

S1 Largest pitch (max. pitch)
 S2 Pitch between the nozzles (min./max. pitch)
 S3 Pitch between the nozzles, taking connecting element and spacer into account (min./max. pitch)

- ① Screw connection close to manifold
- ② High-temperature insulation plate
- ③ Heating connections
- ④ Possible pin position
- ⑤ Opening and plug location dependent upon nozzle type

Manifold height (VH)

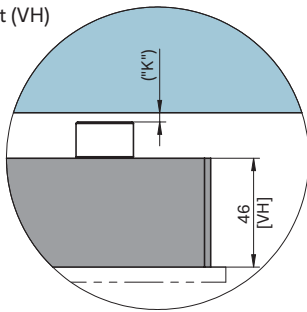

Dimension "K" required for heat expansion is to be ensured by grinding the pressure piece (12 + 0.1 mm)! Determine the difference between the height of the manifold system and the height of the frame plate when installed! ΔT specifies the temperature differential between the processing temperature and the mould temperature!

| VH | ΔT (°C) | 100 | 150 | 200 | 250 | 300 | 350 |
|-------|-----------------|-------|-------|-------|-------|-------|-------|
| 46 mm | K (mm) | 0.033 | 0.078 | 0.124 | 0.170 | 0.218 | 0.264 |

Design examples/Balancing

| Type | | Melt channel \varnothing in mm | Number of drops |
|--------------|--|----------------------------------|-----------------|
| GDP1B | | ≥ 12 to 16 | 1 |
| GDP2B | | ≥ 12 to 16 | 2 |
| GDP3- | | ≥ 12 to 16 | 3 |
| GDP3T | | ≤ 6 | 3 |
| GDP4B | | ≤ 12 to 16 | 4 |
| GDP6T | | ≤ 8 | 6 |

B = balanced T = partially balanced - = not balanced