



## Valve gate nozzle type 6NMT

System nozzle with conventional heating element, for minimal spacing, not screwed to the manifold

### TECHNICAL DATA

#### 6NMT

Needle Ød	3 mm
Melt channel Ød	6 mm
Gate point Ød	0.8, 1.0, 1.2 or 1.4 mm
Operating voltage	230 V <sub>AC</sub> *

#### Nominal length of the nozzle (L) in mm

50	60	80	100	120	150	200
■	■	■	■	□	□	□

Contact us for other nozzle lengths!

\*Volts alternating current

■ available □ on request



WEBCODE  
32100



Nozzle with needle guide  
antechamber design LA

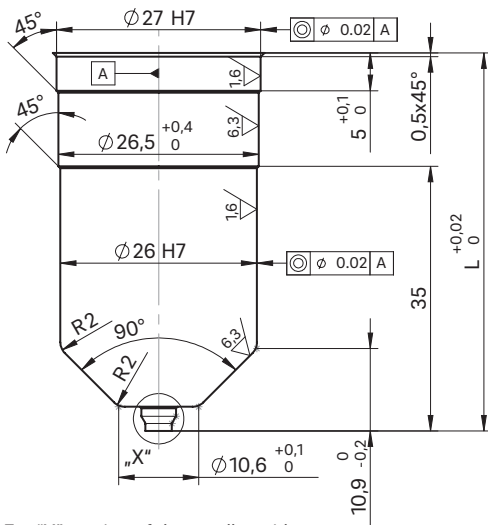

For "X" version of the needle guide  
see following page

Nozzle with needle guide  
antechamber design KA

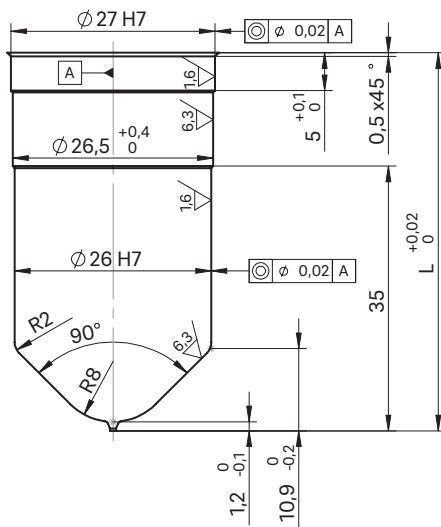

## INSTALLATION

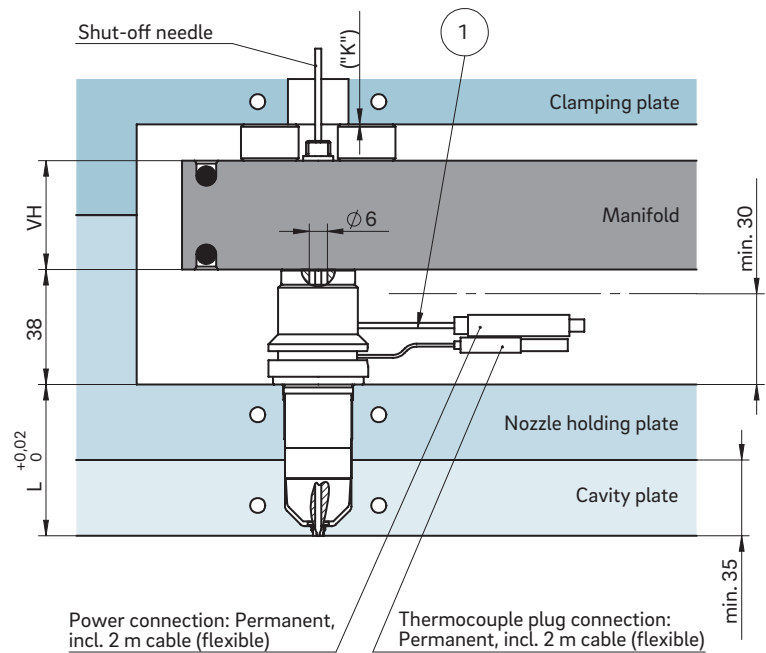

Example cutout for nozzle head, power and thermocouple plug connections

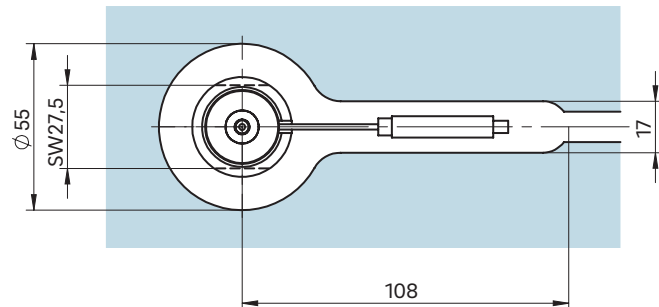

- ① Power and thermocouple plug connections in this area can be bent once; minimum radius: R8  
SW = flat area on nozzle head

Dimension "K" required for heat expansion is to be ensured by grinding the pressure pad (12 + 0.1 mm)! Determine the difference between the height of the manifold system and the height of the frame plate when installed! ΔT specifies the temperature differential between the processing temperature and the mould temperature!

VH	ΔT (°C)	100	150	200	250	300	350
36 mm	K (mm)	0.021	0.059	0.098	0.137	0.177	0.217
46 mm	K (mm)	0.033	0.078	0.124	0.170	0.218	0.264
56 mm	K (mm)	0.046	0.097	0.150	0.203	0.258	0.311



# Valve gate nozzle type 6NMT

Needle guide versions LA, LA with titanium ring, LAZ and KA

## NEEDLE GUIDE VERSIONS



Needle guide version  
Antechamber version LA

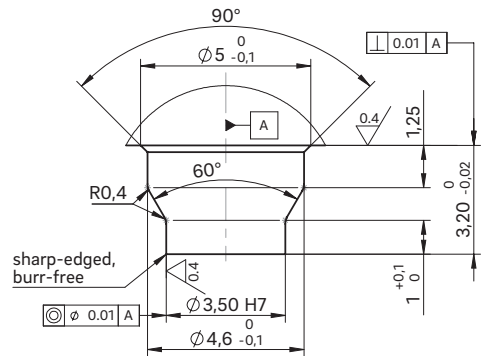
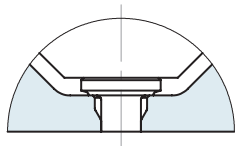

### Needle guide LA

Made of powder-metallurgical steel

If necessary, the needle guide can be changed without great effort. By replacing the needle guide and needle, the gate point diameter can be made larger or smaller without subsequent reworking of the mould cavity. Thanks to a precise needle guide, the clean gate point can be closed with nearly no wear or burring.

### Advantages:

- Long service life and wear-resistance
- Wear parts are easy to replace
- Outstanding and flash-free gate point quality
- Very good visual surface quality
- No replacement or subsequent reworking of the mould inserts required
- Minimal shear stress



Needle guide version  
Antechamber version LA  
with titanium ring

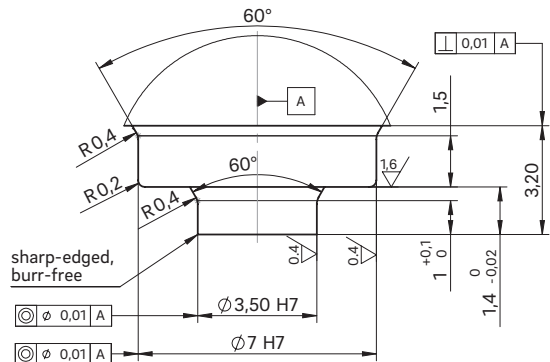
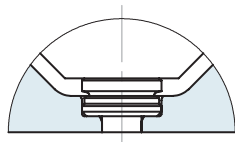

### Needle guide LA

Special version with titanium ring

Thermal insulation of the needle guide using a titanium ring expands the area of use of the valve gate nozzle to include the following plastics:

- Polyamides (PA4.6, PA6.6 and HTN)
- Thermoplastic polyesters (PBT and PET)
- Liquid crystalline polymers (LCP)
- Polyether ether ketones (PEEK)



**Installation dimensions of needle guide version LAZ**

ØD	ØS7	t6
0.8	2.2	0.91
1.0	2.4	1.05
1.2	2.6	1.20
1.4	2.8	1.34



Needle guide version  
Antechamber version LAZ

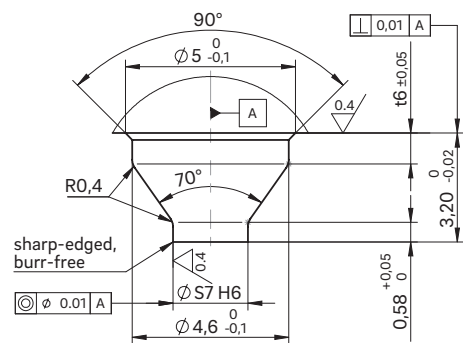
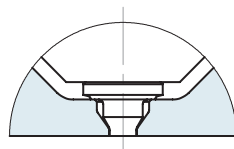

**Needle guide LAZ**

Made of powder-metallurgical steel

If necessary, the needle guide can be changed without great effort. By replacing the needle guide and needle, the gate point diameter can be made larger or smaller without subsequent reworking of the mould cavity. Thanks to a precise needle guide, the clean gate point can be closed with nearly no wear or burring. Needle guide type LAZ has a tapered shape with a smaller contact surface which creates a smaller impression. This version is suitable for items with a minimal wall thickness and part geometries not permitting a larger impression.

**Advantages:**

- Long service life and wear-resistance
- Wear parts are easy to replace
- Outstanding and flash-free gate point quality
- Very good visual surface quality
- No replacement or subsequent reworking of the mould inserts required
- Minimal shear stress



Needle guide version  
Antechamber version KA

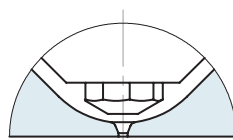

**Needle guide KA**

This is used when a second marking on the part is not permissible.

When selecting the material to be used, the needle hardness of 64 ±2 HRC is to be taken into account!

