







# Index

---

Hot halves		Page
RapidFlow®		7. 10
CADHOC®		7. 20
54-cavity		7. 30
16-cavity valve-gate		7. 40

# RapidFlow® hot half type HS 93/ -94/ -96

## HS 93

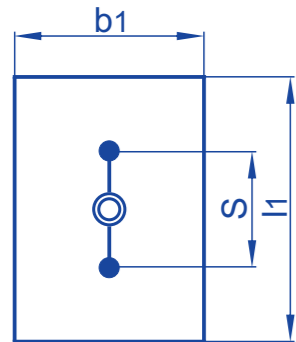

Pitch centers "S" (mm)	Plate size (minimum) b1 x l1 (mm)	Manifold size VL x VB x VH (mm)
80 - 140	196 x 296	210 x 100 x 46
>140 - 190	196 x 346	260 x 100 x 46
>190 - 240	196 x 396	310 x 100 x 46
>240 - 290	196 x 446	360 x 100 x 46

When ordering, please always specify the "S" pitch centers.  
Example:  
Pitch centers "S" = 200 mm

## HS 94

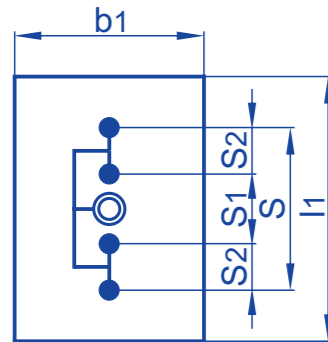

Smallest pitch centers S1= 80 mm, S2= 40 mm

Pitch centers "S" (mm)	Plate size (minimum) b1 x l1 (mm)	Manifold size VL x VB x VH (mm)
160 - 190	196 x 346	260 x 100 x 46
>190 - 240	196 x 396	310 x 100 x 46
>240 - 290	196 x 446	360 x 100 x 46

When ordering, please always specify the "S1" and "S2" pitch centers.  
Example:  
Pitch centers "S1" = 100 mm, "S2" = 60 mm, ("S" = 220 mm)

## HS 96

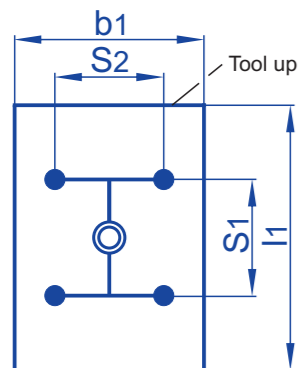

S1 ≥ S2

Pitch centers (mm)		Plate size (minimum) b1 x l1 (mm)	Manifold size VL x VB x VH (mm)
S1	S2		
50 - 70	50 - 70	246 x 296	140 x 140 x 46
70 - 110	50 - 70	246 x 346	180 x 140 x 46
110 - 150	50 - 70	246 x 396	220 x 140 x 46
150 - 190	50 - 70	246 x 446	260 x 140 x 46
190 - 230	50 - 70	246 x 446	300 x 140 x 46
70 - 110	70 - 110	296 x 346	180 x 180 x 46
110 - 150	70 - 110	296 x 396	220 x 180 x 46
150 - 190	70 - 110	296 x 446	260 x 180 x 46
190 - 230	70 - 110	296 x 446	300 x 180 x 46
110 - 150	110 - 150	346 x 396	220 x 220 x 46
150 - 190	110 - 150	346 x 446	260 x 220 x 46
190 - 230	110 - 150	346 x 446	300 x 220 x 46

When ordering, please always specify the "S1" and "S2" pitch centers.  
Example:  
Pitch centers "S1" = 140 mm, "S2" = 100 mm

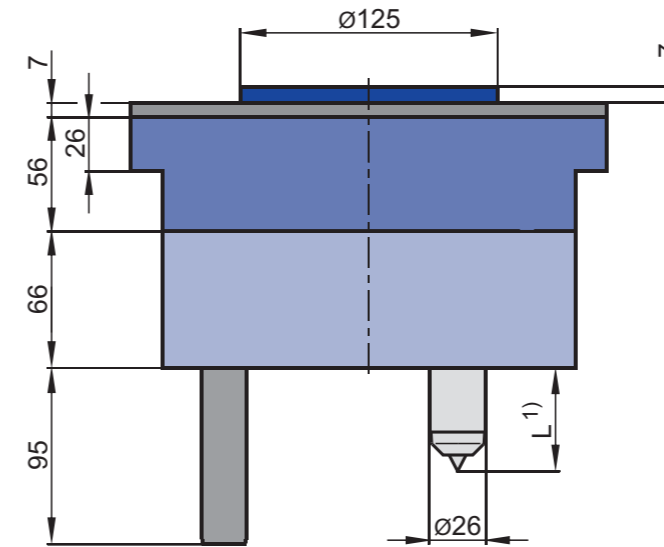

View on the nozzle tip

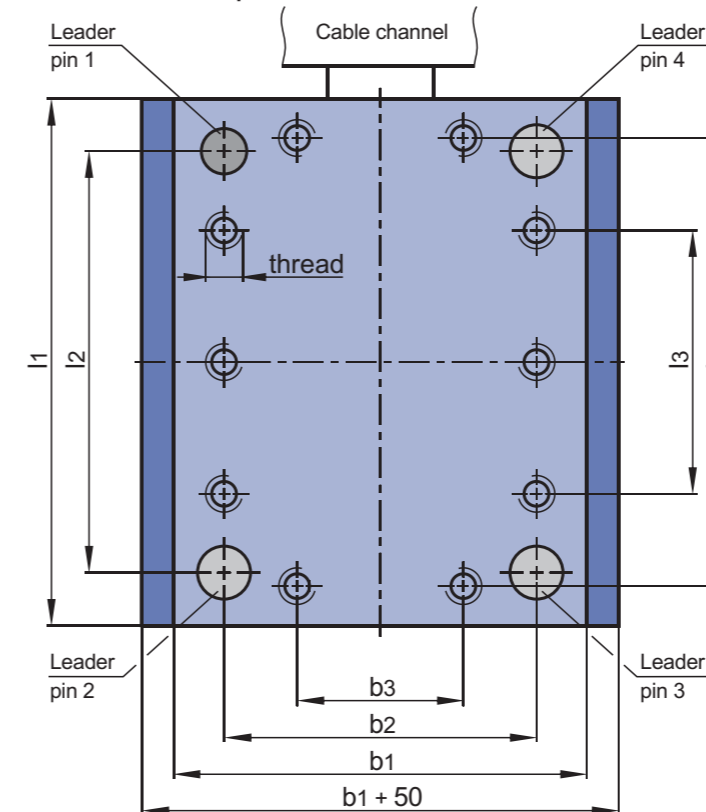

### Product description

RapidFlow® hot half with temperature regulation and locating ring (Ø125 mm).  
Nozzle type 6SRT, screwed into the manifold.  
Separate power and temperature connections.  
Connections for tempering G1/4".  
Tapped holes for transport purposes all around.  
1) Nozzle projecting "L" 50, 60, 80 mm.

### Notes

Delivery time 3 weeks.  
Completely assembled and wired.  
Ready-to-install solution.  
Attractive price-performance ratio.  
In proven GÜNTHER quality.

### Hasco - 01

Plate size b1 x l1 (mm)	b2	b3	l2	l3	l4	Thread	Leader pin (Ø)	
							1	2, 3, 4
196 x 296	150	80	244	186	260	M12	22	24
196 x 346	150	80	294	236	310	M12	22	24
196 x 396	144	80	344	274	360	M12	22	24
196 x 446	144	80	394	324	410	M12	22	24
246 x 296	200	130	244	186	260	M12	22	24
246 x 346	194	130	294	224	310	M12	22	24
246 x 396	198	130	340	284	360	M12	22	24
246 x 446	194	130	394	324	410	M12	22	24
296 x 296	250	180	244	186	260	M12	22	24
296 x 346	244	180	294	224	310	M12	22	24
296 x 396	248	180	340	284	360	M12	22	24
296 x 446	244	180	394	324	410	M12	22	24
346 x 346	294	180	294	224	310	M12	22	24
346 x 396	274	180	316	230	360	M16	30	32
346 x 446	274	180	374	280	410	M16	30	32

### Meusburger - 02

Plate size b1 x l1 (mm)	b2	b3	l2	l3	l4	Thread	Leader pin (Ø)	
							1	2, 3, 4
196 x 296	156	80	256	186	260	M10	18	20
196 x 346	148	80	298	220	310	M12	22	24
196 x 396	148	80	348	270	360	M12	22	24
196 x 446	148	80	398	320	410	M12	22	24
246 x 296	198	130	248	170	260	M12	22	24
246 x 346	198	130	298	220	310	M12	22	24
246 x 396	198	130	348	270	360	M12	22	24
246 x 446	198	130	398	320	410	M12	22	24
296 x 296	248	180	248	170	260	M12	22	24
296 x 346	248	180	298	220	310	M12	22	24
296 x 396	248	180	348	270	360	M12	22	24
296 x 446	248	180	398	320	410	M12	22	24
346 x 346	298	180	298	220	310	M12	22	24
346 x 396	274	180	324	230	360	M16	30	32
346 x 446	274	180	374	280	410	M16	30	32



### Ordering notes

In addition to your other specifications, add the pitch centers, radius or angle (freely selectable depending on the injection unit) and the code number of the supplier (01 or 02).

Please indicate material type, article and part weight and kind of gating in your order.

Order number	Pitch center (mm)		Radius	Angle	Nozzle projecting (L) mm			Supplier of plate		Quantity ordered	Delivery time	
	S	S1			S2	R	W	50	60			80
HS 93		X	X									
HS 94												
HS 96	X											

### Please provide the following informations

Part description: \_\_\_\_\_ Part wall thickness: \_\_\_\_\_ mm Shot weight by nozzle: \_\_\_\_\_ g

Application area/ industry: \_\_\_\_\_

Type of material: \_\_\_\_\_ Manufacturer details: \_\_\_\_\_

Type of gating: Direct   
Indirect

### Example: You choose ...

- |                                |         |                            |
|--------------------------------|---------|----------------------------|
| 1. Hot half series 96          | (HS 96) | <b>HS 96</b>               |
| 2. Plate width (b1) 296 mm     | (296)   | <b>HS 96 296</b>           |
| 3. Plate length (l1) 396 mm    | (396)   | <b>HS 96 296 396</b>       |
| 4. Nozzle projecting (L) 80 mm | (08)    | <b>HS 96 296 396 08</b>    |
| 5. Supplier of plate "Hasco"   | (01)    | <b>HS 96 296 396 08 01</b> |

### Order number

The order number for the selected "RapidFlow®" hot half with a plate width of 296 mm, plate length 396 mm and nozzle projecting 80 mm is: **HS 96 296 396 08 01**.

## CADHOC® hot halves

### Product description

By using the **GÜNTHER System-Designer CADHOC®** to configure hot halves, you can save time and money by means of de-tailed data at an early project phase.

Hot halves based on the type of manifold  
 - Straight manifold, 2-drop, 4-drop  
 - H-manifold, 4-drop, 8-drop  
 - Cross manifold, 4-drop

Plate sizes from 246 x 296 mm to 796 x 996 mm (depending on size of manifold and type of manifold).

Scope of delivery: Hot halves in 2-plate-system, including guide elements, cable channel, cooling, etc.

All system nozzles with tip and open nozzle piece can be used.

### The “hot halves” are ready-to-install with many benefits

Focussing on your requirements, we'll design the solution most appropriate for you. You'll get a sophisticated tool concept, in which all components are compatible.

#### Efficient and inexpensive

Complete mould halves with height-adjusted hot-runner and without cavity plate for all areas of industry eliminate installation errors, reduce project planning expenses, and maximize the performance of GÜNTHER hot-runner systems.

#### Advantages of our wide range of hot half products

From the top edge of the article, we'll supply a complete tool half with height-adjusted hot-runner. Completely wired and function-tested. With this ready-to-install solution, you are able to avoid elaborate fine-tuning work and possible installation errors. We deliver hot halves with valve gate technology with either an electric, hydraulic or pneumatic drive.

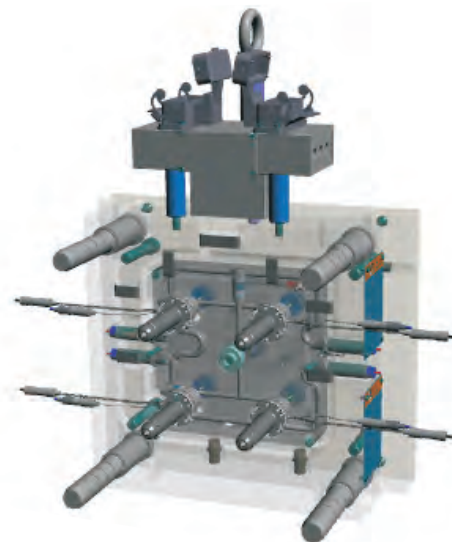

### Your benefits at a glance

- **Ready-to-install solution.**  
Hot half is delivered fully wired, assembled and function-tested. Eliminates installation errors and is efficient, since no elaborate fine-tuning work is required.
- **Eliminates additional fitting costs caused by reworking on defective hot-runners.**  
Cost savings through rapid mould construction.
- **Shortened project planning times,** since the construction of the mould only has to be concentrated only on the ejection side and cavity plate. Project planning runs parallel to mould planning.
- **Online configuration using the CADHOC® System-Designer.**  
The system suggests plate sizes.
- **Extended warranty period** for hot halves which are operated with the latest GÜNTHER controllers and GÜNTHER connecting components.

**CADHOC®**  
 GÜNTHER System-Designer  
[www.guenther-heisskanal.de/cadhoc](http://www.guenther-heisskanal.de/cadhoc)

## Hot half 54-cavity

### Product description

#### Hot half composed of:

##### Manifold data:

- HEP6B
- Sub-distribution (6 unit)

##### Nozzle type:

- 3STF120S

#### The “hot halves” are ready-to-install with many benefits

Focussing on your requirements, we'll design the solution most appropriate for you. You'll get a sophisticated tool concept, in which all components are compatible.

#### Efficient and inexpensive

Complete mould halves with height-adjusted hot-runner and without cavity plate for all areas of industry eliminate installation errors, reduce project planning expenses, and maximize the performance of GÜNTHER hot runner systems.

#### Advantages of our wide range of hot half products

From the top edge of the article, we'll supply a complete tool half with height-adjusted hot-runner. Completely wired and function-tested. With this ready-to-install solution, you are able to avoid elaborate fine-tuning work and possible installation errors. We deliver hot halves with valve gate technology with either an electric, hydraulic or pneumatic drive.

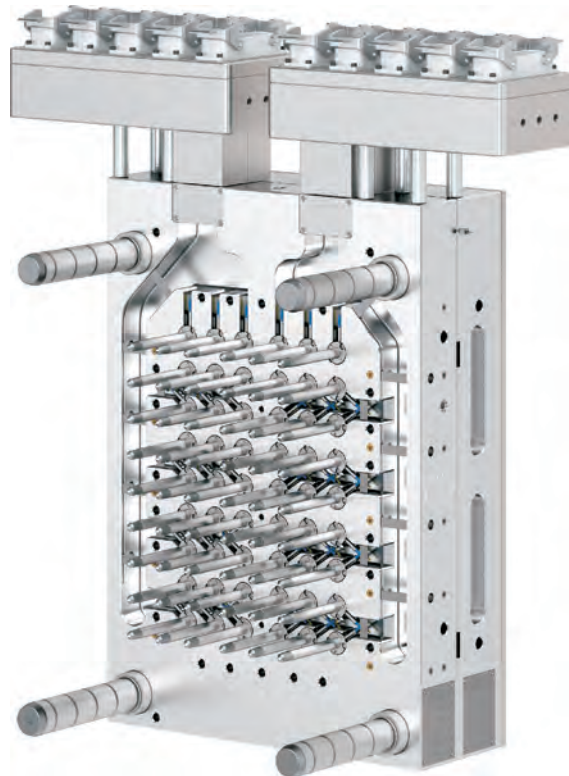

### Your benefits at a glance

- **Ready-to-install solution.**  
Hot half is delivered fully wired, assembled and function-tested. Eliminates installation errors and is efficient, since no elaborate fine-tuning work is required.
- **Eliminates additional fitting costs caused by reworking on defective hot-runners.**  
Cost savings through rapid mould construction.
- **Shortened project planning times**, since the construction of the mould only has to be concentrated only on the ejection side and cavity plate. Project planning runs parallel to mould planning.
- **Online configuration using the CADHOC® System-Designer.**  
The system suggests plate sizes.
- **Extended warranty period** for hot halves which are operated with the latest GÜNTHER controllers and GÜNTHER connecting components.

## Hot half 16-cavity valve-gate

### Product description

#### Hot half composed of:

##### Needle actuator

- Sliding cam mechanism ANES/ E
- Actuator: Servomotor

##### Manifold data:

- NHCP16B

##### Nozzle type:

- 5NTT50
- PM-needle guide type LAZ 0,8 mm

#### The “hot halves” are ready-to-install with many benefits

Focussing on your requirements, we'll design the solution most appropriate for you. You'll get a sophisticated tool concept, in which all components are compatible.

#### Efficient and inexpensive

Complete mould halves with height-adjusted hot-runner and without cavity plate for all areas of industry eliminate installation errors, reduce project planning expenses, and maximize the performance of GÜNTHER hot runner systems.

#### Advantages of our wide range of hot half products

From the top edge of the article, we'll supply a complete tool half with height-adjusted hot-runner. Completely wired and function-tested. With this ready-to-install solution, you are able to avoid elaborate fine-tuning work and possible installation errors. We deliver hot halves with valve gate technology with either an electric, hydraulic or pneumatic drive.

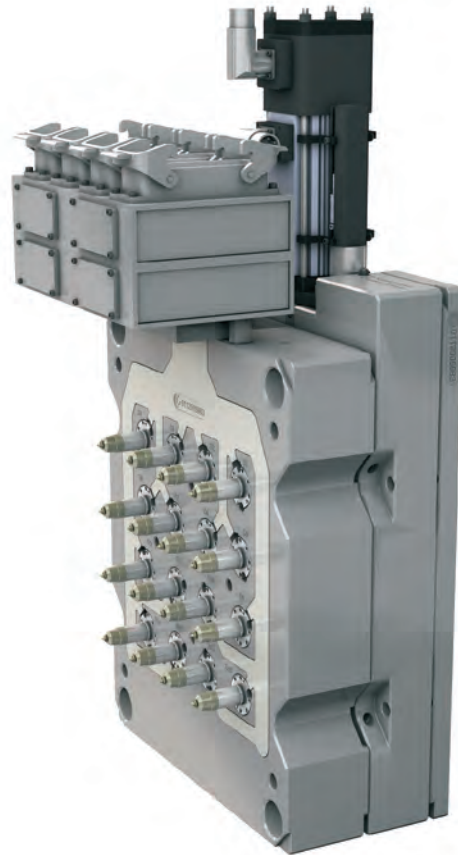

### Your benefits at a glance

- **Ready-to-install solution.**  
Hot half is delivered fully wired, assembled and function-tested. Eliminates installation errors and is efficient, since no elaborate fine-tuning work is required.
- **Eliminates additional fitting costs caused by reworking on defective hot-runners.**  
Cost savings through rapid mould construction.
- **Shortened project planning times**, since the construction of the mould only has to be concentrated only on the ejection side and cavity plate. Project planning runs parallel to mould planning.
- **Online configuration using the CADHOC® System-Designer.**  
The system suggests plate sizes.
- **Extended warranty period** for hot halves which are operated with the latest GÜNTHER controllers and GÜNTHER connecting components.