

Technical Information

Needle drive actuation for valve gate systems

A needle drive is required to move the needles to the „open“ or „closed“ position in a hot runner valve gate system. Different drive options are available for the needle drive.

- **Single needle valve nozzle (NEST/NESF)**
- **Single needle valve (ENV/EEV)**
- **Stepper motor drive (SMA 10)**
- **Lifting mechanism (ANEH)**
- **Sliding mechanism (ANES)**

A pneumatic or hydraulic system is available as the drive type to actuate the individual needle valves and for the lifting and sliding mechanism. The sliding mechanism can also be driven by a servo motor as an alternative. The single needle valve nozzle is operated pneumatically only.

Pneumatic and hydraulic drives require an adequately high pressure [bar] and a high flow volume [l/min] to achieve the required needle closing force of approx. 1000 N and move the needles quickly and steadily (ENV/EEV).

The following guide values apply for pressures for pneumatic or hydraulic needle drive actuation:

| | |
|--------------------------------------|---|
| NEST/NESF Nozzle | 8 ... 10 bar <i>(recommended: 10 bar)</i> |
| Single needle valve (ENV/EEV) | Pneumatic 6 – 8 bar |
| | Hydraulic approx. 40 bar |
| Lifting mechanism | Pneumatic 6 – 8 bar |
| | Hydraulic 40 – 60 bar |
| Sliding mechanism | Pneumatic 6 – 8 bar |
| | Hydraulic 40 – 60 bar |

Higher pressures may be required in individual cases.

Technical Information ■ Needle drive actuation for valve gate systems

The drive medium flow rate (air/oil) affects both the speed and constancy of the needle movement. In our experience, the following values are best for the flow volume:

| | | |
|---------------------------------------|-------------------|----------------|
| NEST/NESF Nozzle | Pneumatic | 3000 l/min |
| Single needle valve (ENV/EEV) | Hydraulic | 30 – 40 l/min |
| | Pneumatic 4 imp. | 2000 l/min |
| | Pneumatic 8 imp. | 3000 l/min |
| | Pneumatic 16 imp. | 2 x 3000 l/min |
| Lifting/ sliding mechanism | Hydraulic | 30 – 40 l/min |
| | Pneumatic | 3000 l/min |

Please note that the valve for controlling needle drives must be designed for the specified flow rates. The tubing and the connections and feed channels in the clamping plate must also be suitably designed. We recommend an outer hose diameter of min. 8 mm, with 10 mm preferred. The distance between the valve and the pressure consumer must be as short as possible.

A needle movement interval (closing/opening) of 100 and 150 ms can be assumed for needle drive hydraulic actuation (e. g. ENV).

The movement interval for needles in a valve gate system with a sliding mechanism and servo motor is approx. 500 ms (30 mm piston travel; $v = 200 \text{ mm/s}$; $a = 500 \text{ mm/s}^2$).

The effective movement interval for a needle with a stepper motor drive is between 400 ms (7 mm stroke) and 600 ms (10 mm stroke), depending on the needle stroke ($v = 20 \text{ mm/s}$; $a = 100 \text{ mm/sec}^2$ and ramp sine „1“).

When designing the moulds, adequate temperature control must be provided around the valve gate drive concerned when using valve gate drives. This is to ensure uniform thermal expansion of the mould plates and effective heat dissipation to avoid overheating the needle drives. Even after the process has ended, heat still needs to be dissipated via the temperature control to avoid damaging the plastic and the hot runner.

Technical Information ■ Needle drive actuation for valve gate systems

The following maximum temperatures apply for single needle valves (ENV/EEV):

| | | |
|----------------------------|-------------|--|
| Pneumatic actuators | 100 – 120°C | <i>(affects the sealing rings)</i> |
| Hydraulic actuators | *60°C | <i>(hydraulic fluid viscosity and thermal damage to the fluid)</i> |

* We recommend tempering the clamping plate separately to prevent overheating of the needle drives and the hydraulic oil. In our experience, the temperature of the clamping plate should not exceed 60°C to prevent premature ageing and a reduction in the viscosity of the hydraulic oil. In this context, the instructions / data sheets of the machine and mineral oil manufacturers must be observed. The seals installed in the single needle valves (ENV and EEV) are designed for temperatures up to 100°C.

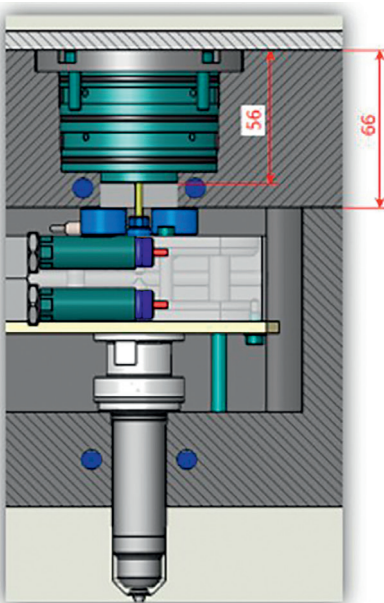

Figure:
Clamping plate temperature control
in the needle drive section

When using electric drives (stepper motors), the ambient temperature for the motors must not exceed 60 °C.

In hydraulic systems, cylinders should be filled with hydraulic fluid at a low speed first. The cylinders should then be bled immediately after filling and after a short running time.

All control circuits can be switched off simultaneously when the hot runner system is switched off. To avoid damage to the hot runner system (needle drives) and the plastic in the manifold due to heat build-up, mould cooling must remain at approx. 30 °C for between 45 and 90 minutes, depending on the size of the manifold. The shut-off needles should be in the „closed“ position.