



**Multi-drop
hot runner nozzles**



4.3 Connecting elements

HEATED ADAPTERS

Page



AHJ5

Heated adapter for using LHF/LHT nozzles as a single nozzle

20



AHJ8

Heated adapter for use of OktaFlow nozzle type 8OHT as a single nozzle

30



Heated adapter type AHJ5

Heated adapter for using LHF/LHT nozzles as a single nozzle

TECHNICAL DATA

AHJ5

Operating voltage 230 V_{AC} *

Adapter straight (G)/radius (R)/
angle (W)

Can be used with nozzle type/Delivery times:

Type	18LHF	22LHT	26LHT
AHJ5	■	■	■

*Volts alternating current

■ Short delivery time

NOTE

Recommended for processing thermally sensitive plastics.

Using a heated adapter, the nozzle types specified above can also be used as single nozzles.

Specify the machine nozzle version when ordering.



Detail "Z"

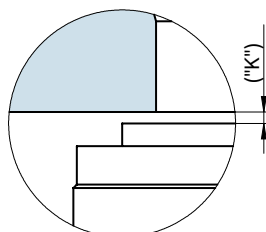

Dimension "K" required for heat expansion is to be ensured by grinding the locating ring! Determine the difference between the height of the nozzle (with adapter) and the height of the structure when installed! ΔT specifies the temperature differential between the processing temperature and the mould temperature!

ΔT (°C)	100	150	200	250	300	350
K (mm)	0.06	0.08	0.09	0.11	0.13	0.16

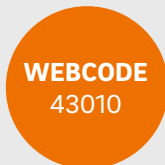



INSTALLATION

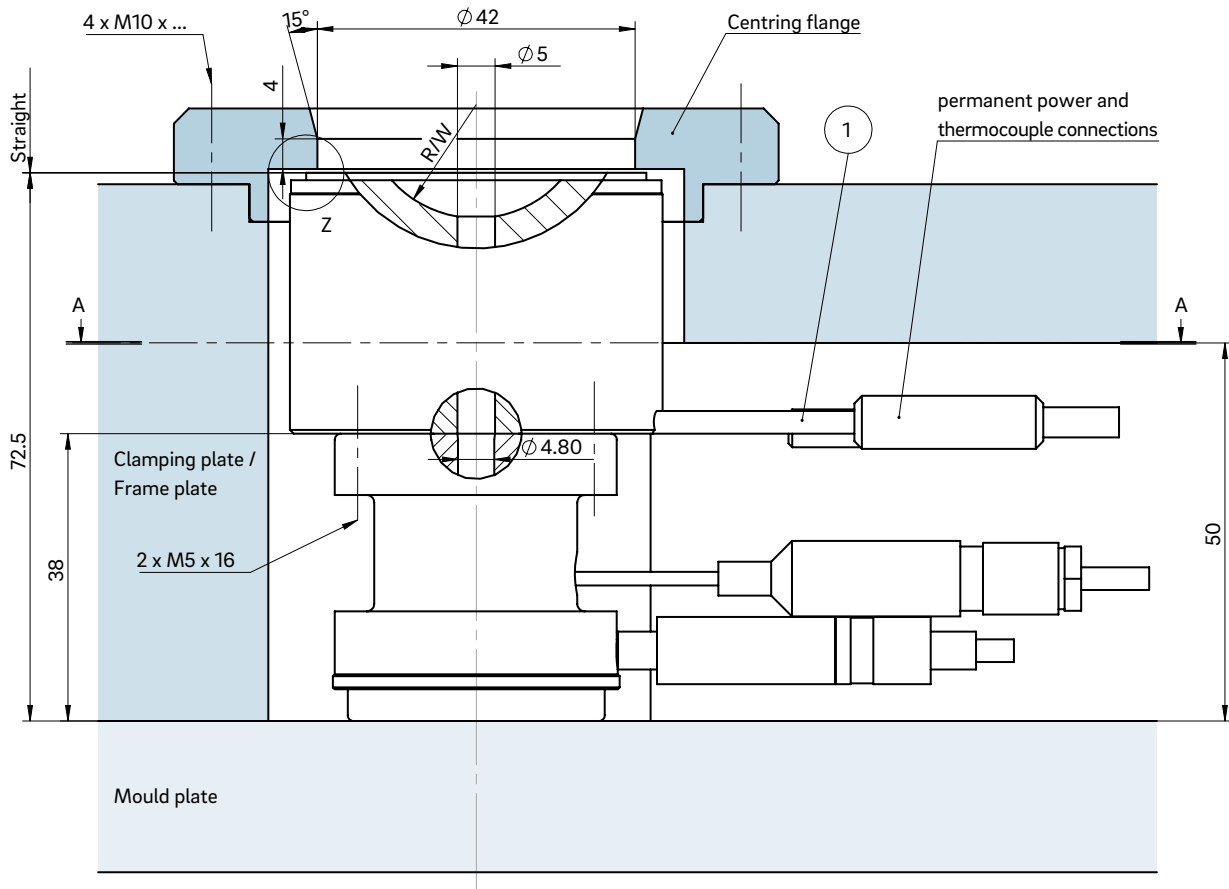

Cross-section A-A: Cutout for heated adapter AHJ5

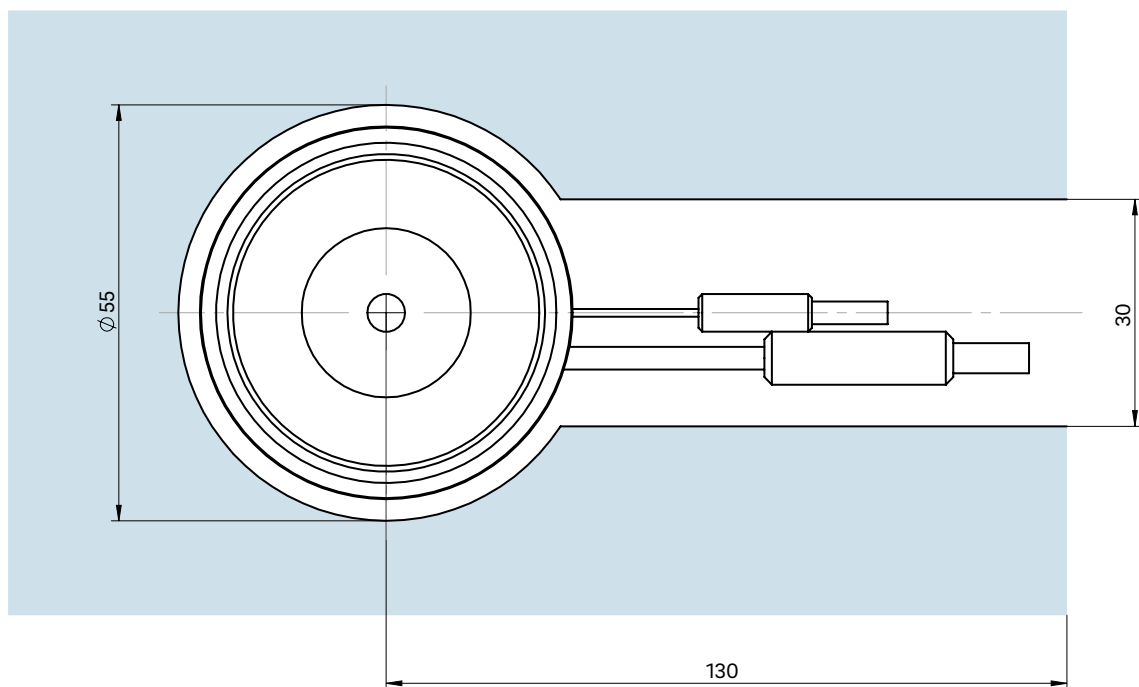

① Power and thermocouple plug connections in this area can be bent once; minimum radius: R8



Heated adapter type AHJ8

Heated adapter for use of OktaFlow nozzle type 8OHT as a single nozzle

TECHNICAL DATA

AHJ8

Operating voltage 230 V_{AC} *

Adapter straight (G)/radius (R)/
angle (W)

Can be used with nozzle type/Delivery times:

Type	8OHT
AHJ8	■

*Volts alternating current

■ Short delivery time

NOTE

Recommended for processing thermally sensitive plastics.

Using a heated adapter, the nozzle types specified above can also be used as single nozzles.

Specify the machine nozzle version when ordering.



Detail "Z"

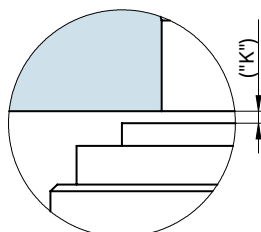

Dimension "K" required for heat expansion is to be ensured by grinding the locating ring! Determine the difference between the height of the nozzle (with adapter) and the height of the structure when installed! ΔT specifies the temperature differential between the processing temperature and the mould temperature!

ΔT (°C)	100	150	200	250	300	350
K (mm)	0.04	0.08	0.12	0.16	0.20	0.25

WEBCODE
43020

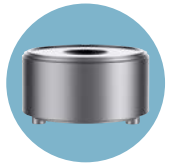

INSTALLATION

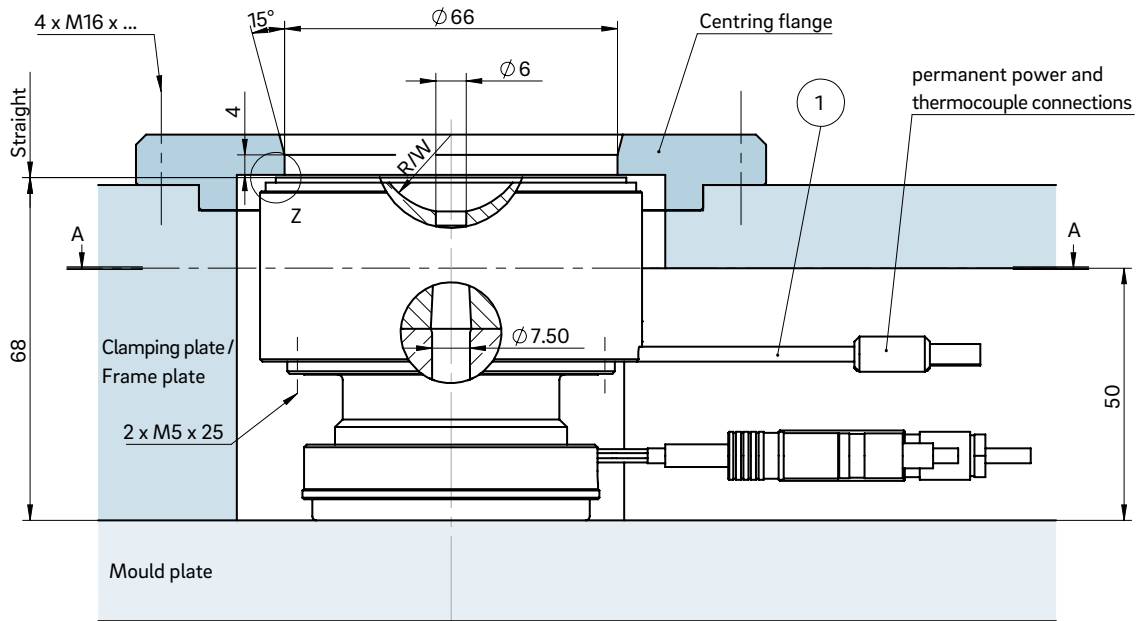

Cross-section A-A: Cutout for heated adapter AHJ8

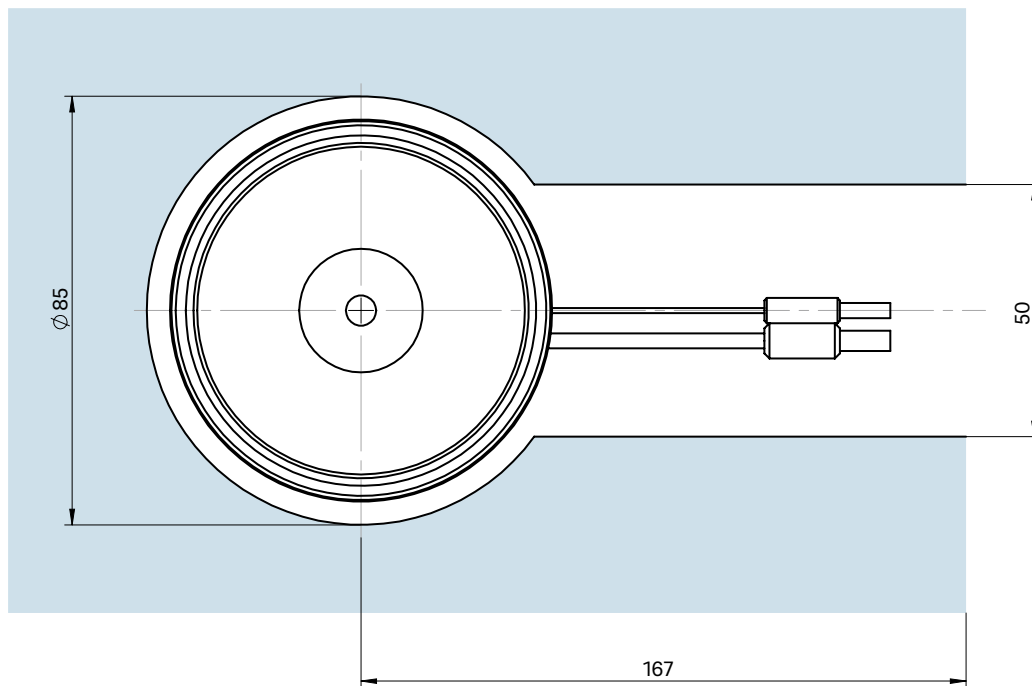

① Power and thermocouple plug connections in this area can be bent once; minimum radius: R8